

## Model G9-113 Rotary Gear Pump

Surex rotary gear pumps designed for foam extinguishing system. They are Self-Priming and can pump Multiple Viscosities of Foam or Water. This versatile design is suitable for Electric, PTO, Diesel/Gasoline Engine, Water Driven or Hydraulic drive motors.

### Design Features:

- Timing Gears Synchronize the Two Pumping Rotors.
- Timing Gears Allow for DRY Running Without Damage.
- No Rotor Contact Allows for Pumping Foam or Water.
- Water Can Be Used for: Calibration, Testing and Training.

### Technical Data:

Max Pressure: 2.0MPa | 20bar  
Max Speed: 1800RPM  
Viscosity : 9500cp max.[1]  
Connection Diameter: DN80(88.9 O.D.)、3"  
Connection Type: Groove、Thread、Flange  
Approvals: FM

[1]Brookfield viscometer, spindle #4, speed 30rpm.



### Materials :

Pump body: Red Brass, ASTM B584 C83600  
Rotor: Stainless Steel 17-4PH  
Red Brass, ASTM B584 C83600  
Liners: Red Brass, ASTM B584 C83600  
Front Cover: Red Brass, ASTM B584 C83600  
Back Cover: Red Brass ASTM B584 C83600  
Timing Gear: Alloy Steel 20CrMnTi (ASTM A29M)  
Lip Seal : FPM

### Performance -Water

Foam Pump	1000rpm			1200rpm			1500rpm			1800rpm			
	Pressure	Flow	Power	Torque	Flow	Power	Torque	Flow	Power	Torque	Flow	Power	Torque
	PSI	GPM	HP	LB-FT	GPM	HP	LB-FT	GPM	HP	LB-FT	GPM	HP	LB-FT
	72.5	109	10	52	142	12	54	191	17	59	233	22	66
	100	101	12	65	134	15	68	183	20	72	228	27	79
	150	90	17	89	122	21	92	172	27	96	218	35	103
	200	82	21	113	114	27	117	163	34	121	209	43	127
	250	76	26	138	108	32	141	157	41	145	201	52	152
	290	74	30	158	105	36	160	153	47	165	196	58	171

### Dimensions

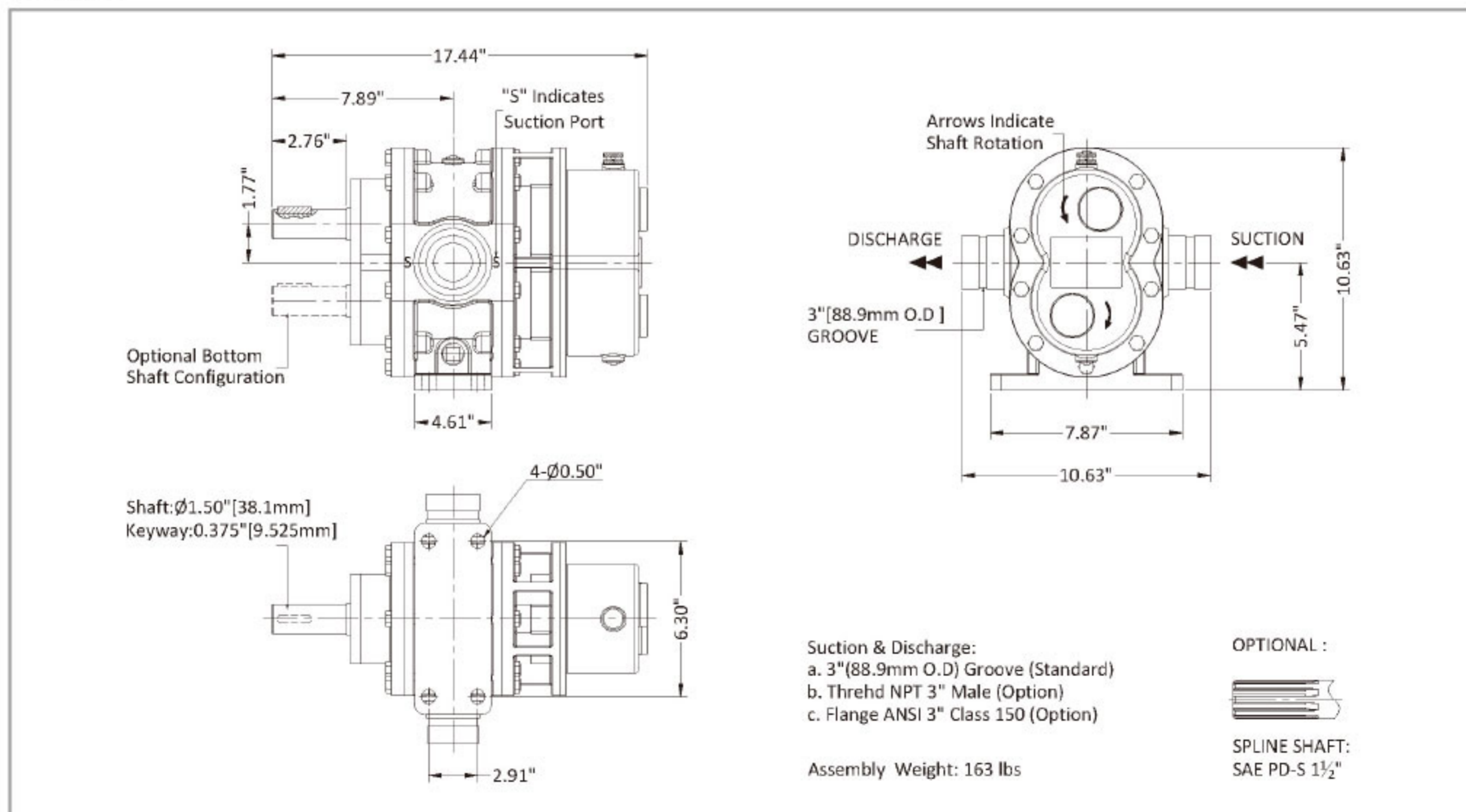

## Model G9-113 Rotary Gear Pump

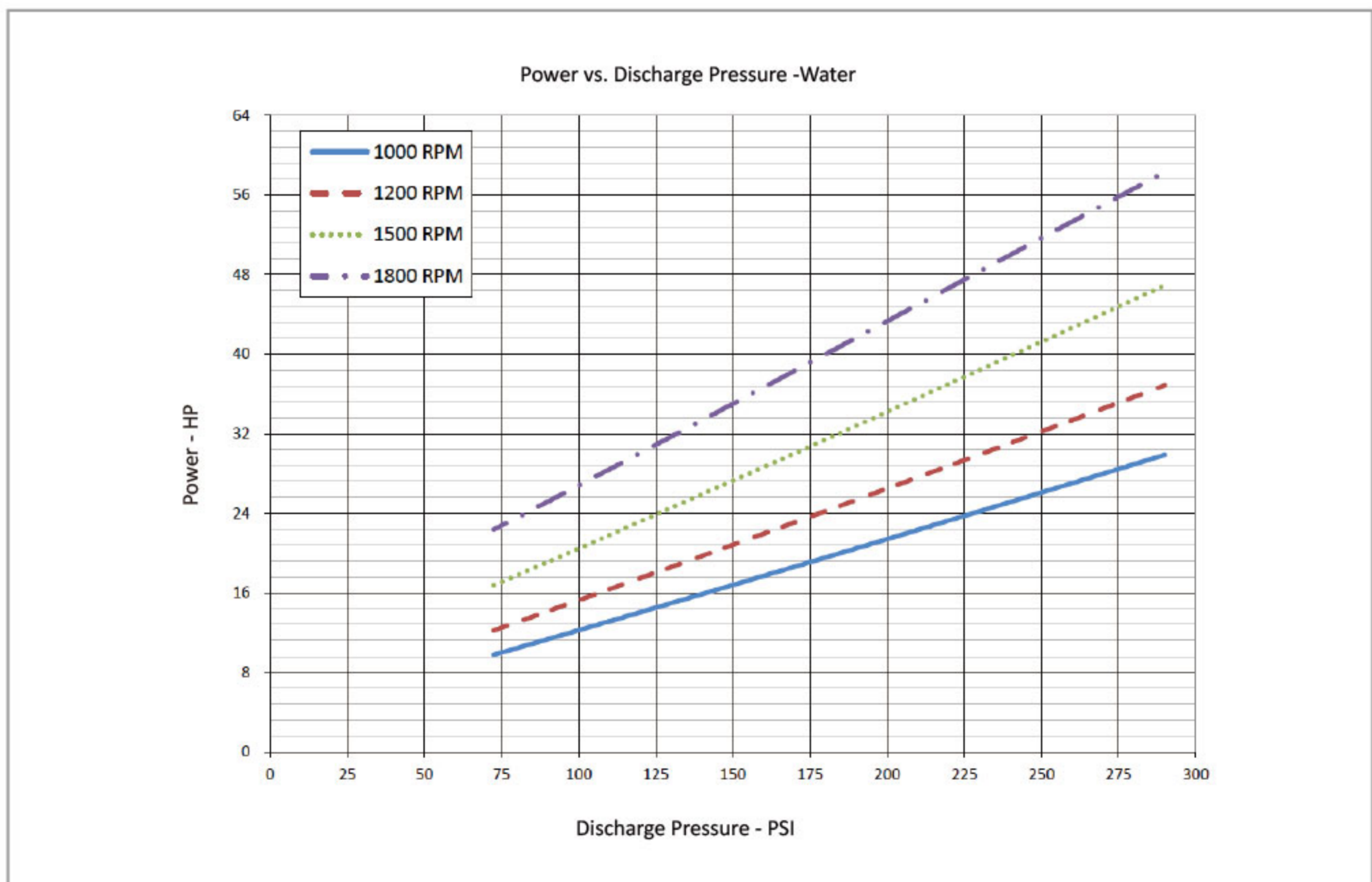
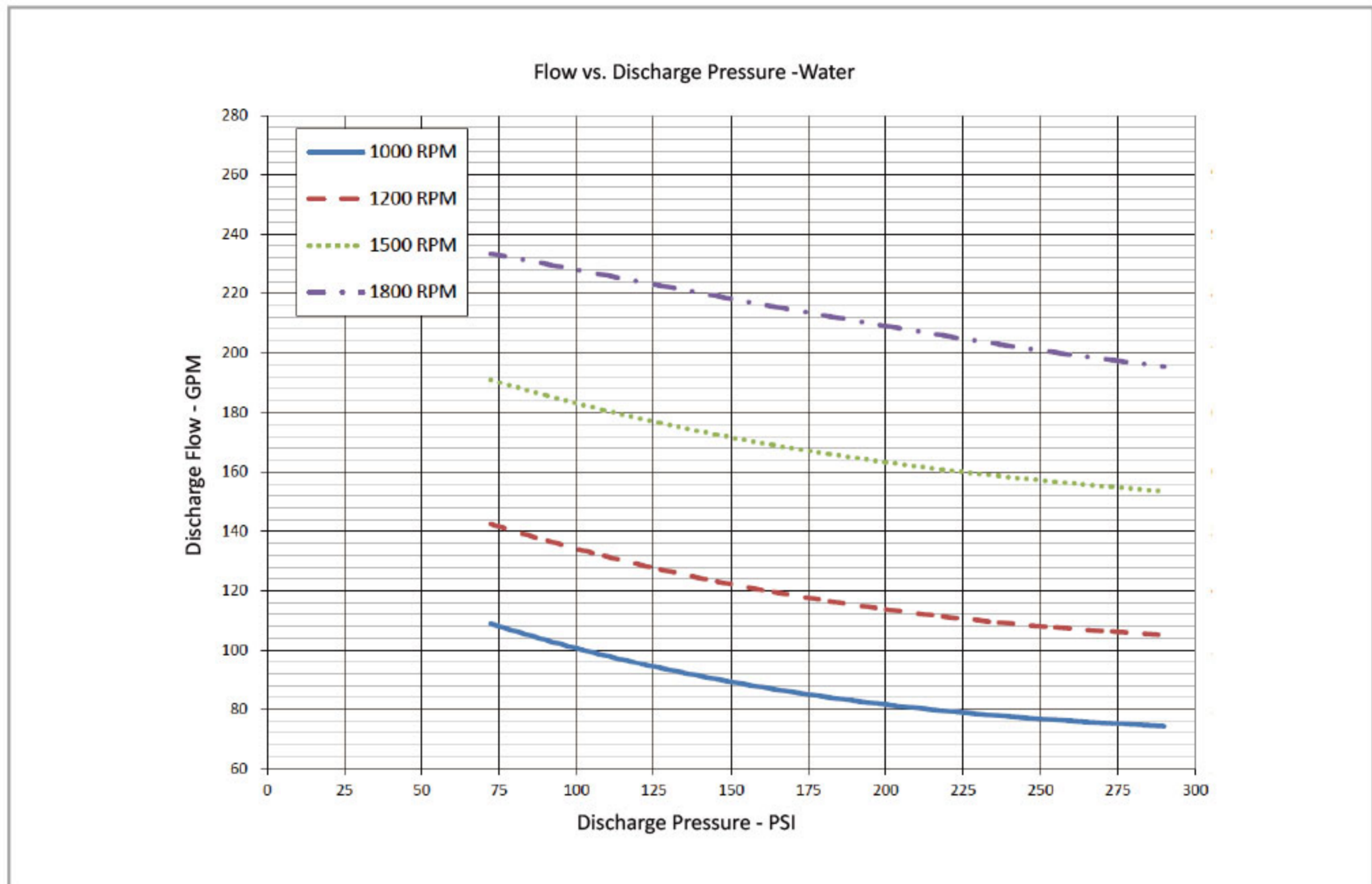

• The pump performance for foam concentrate, please contact Surex, or down load from [www.surexfoam.com](http://www.surexfoam.com).